

Worm Gear Units

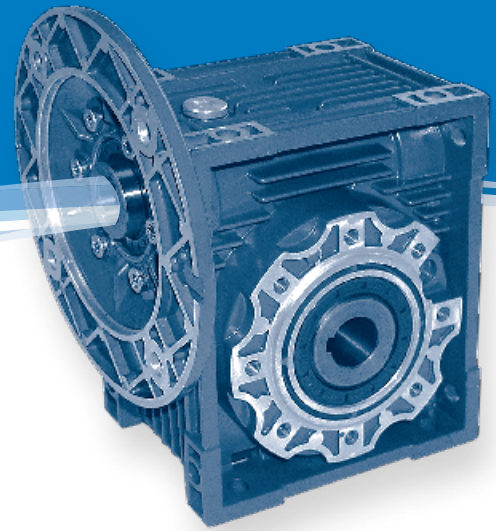

Versions

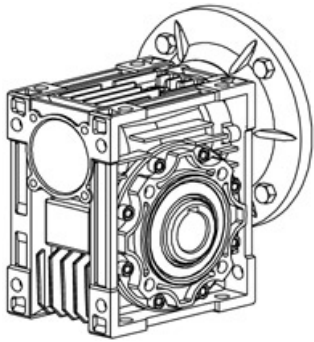

CMRV 025-150

The service factor (f.s.) depends on the operating conditions the reduction unit is subjected to.

The parameters that need to be taken into consideration to select the most adequate service factor correctly comprise:

- type of load of the operated machine : A - B - C
- length of daily operating time: hours/day (Δ)
- start-up frequency: starts/hour (*)

TYPE OF LOAD:	A - uniform	$f_a \leq 0.3$
	B - moderate shocks	$f_a \leq 3$
	C - heavy shocks	$f_a \leq 10$

fa = Je/Jm

- Je (kgm²) moment of reduced external inertia at the drive-shaft
- Jm (kgm²) moment of inertia of motor If $f_a > 10$ call our Technical Service.

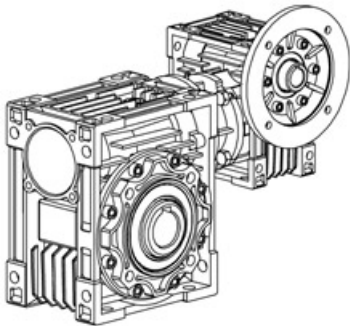

CMRV-CMRV...

A - Screw feeders for light materials, fans, assembly lines, conveyor belts for light materials, small mixers, lifts, cleaning machines, fillers, control machines.

B - Winding devices, woodworking machine feeders, goods lifts, balancers, threading machines, medium mixers, conveyor belts for heavy materials, winches, sliding doors, fertilizer scrapers, packing machines, concrete mixers, crane mechanisms, milling cutters, folding machines, gear pumps.

C - Mixers for heavy materials, shears, presses, centrifuges, rotating supports, winches and lifts for heavy materials, grinding lathes, stone mills, bucket elevators, drilling machines, hammer mills, cam presses, folding machines, turntables, tumbling barrels, vibrators, shredders.

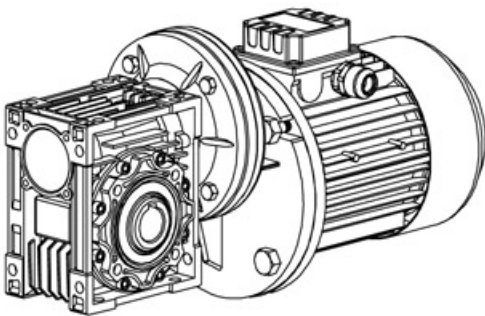

>-CMRV...

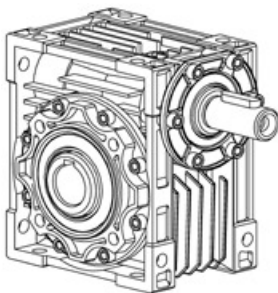
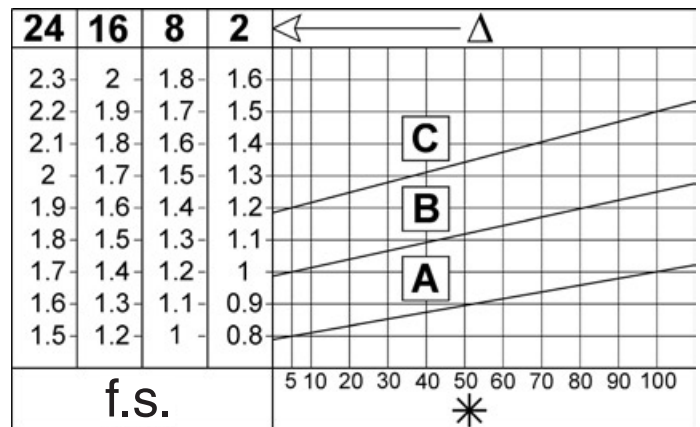

CRV 030-150

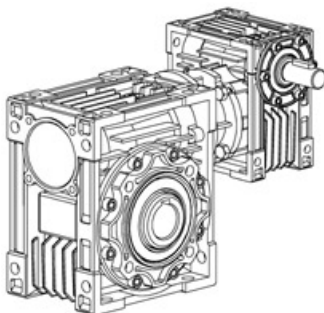

CRV-CMRV...

Direction of Rotation



The helix is right-handed

Critical Applications

The performance given in the catalogue correspond to mounting position B3 or similar, ie. when the first stage is not entirely immersed in oil. For other mounting positions and/or particular input speeds, refer to the tables that highlight different critical situations for each size of reduction unit.

It is also necessary to take due consideration of and carefully assess the following applications by calling our Technical Service:

- As a speed increasing.
- Use in services that could be hazardous for people if the reduction unit fails.
- Applications with especially high inertia.
- Use as a lifting winch.
- Applications with high dynamic strain on the case of the reduction unit.
- In places with T° under -5°C or over 40°C.
- Use in chemically aggressive environments.

- Use in a salty environment.
- Mounting positions not envisaged in the catalogue.
- Use in radioactive environments.
- Use in environments pressures other than atmospheric pressure.

Avoid applications where even partial immersion of the reduction unit is required.

The maximum torque (*) that the gear reducer can support must not exceed two times the nominal torque (f.s.=1) stated in the performance tables.

(*) intended for momentary overloads due to starting at full load, braking, shocks or other causes, particularly those that are dynamic.

CRMV	025	030	040	050	063	075	090	110	130	150
V5: 1500 < n1 < 3000	-	-	-	-	-	B	B	B	B	B
n1 > 3000	B	B	B	B	B	A	A	A	A	A
V6	B	B	B	B	B	B	B	B	B	B

A = Application not recommended

B = Check the application or call technical department

Installation and Lubrication

To install the reduction unit it is necessary to note the following recommendations:

- The mounting on the machine must be stable to avoid any vibration.
- Check the correct direction of rotation of the reduction unit output shaft before fitting the unit to the machine.
- In the case of particularly lengthy periods of storage (4/6 months), if the oil seal is not immersed in the lubricant inside the unit, it is recommended to change it since the rubber could stick to the shaft or may even have lost the elasticity it needs to function properly.
- Whenever possible, protect the reduction unit against solar radiation and bad weather.
- Ensure the motor cools correctly by assuring good passage of air from the fan side.
- In the case of ambient temperatures < -5°C or > +40°C call the Technical Service.
- The various parts (pulleys, gear wheels, couplings, shafts, etc.) must be mounted on the solid or hollow shafts using special threaded holes or other systems that anyhow ensure correct operation without risking damage to the bearings or external parts of the units. Lubricate the surfaces in contact to avoid seizure or oxidation.
- Painting must definitely not go over rubber parts and the holes on the breather plugs, if any.
- For units equipped with oil plugs, replace the closed plug used for shipping with the special breather plug.

- Check the correct level of the lubricant through the indicator, if there is one.
- Starting must take place gradually, without immediately applying the maximum load.
- When there are parts, objects or materials under the motor drive that can be damaged by even limited spillage of oil, special protection should be fitted.
- The reduction units size 025-030-040-050-063-075-090 are supplied complete with lubricant for life, synthetic oil, and can therefore be mounted in any position envisaged in the catalogue. The only exceptions are CMRV090- and CRV075-090- in position. V5/V6 for which you should call our Technical Service to assess the conditions of use.
- The reduction units size 110, 130 and 150 are supplied complete with lubricant, mineral oil.
- For sizes 110, 130 and 150 it is necessary to specify the position, otherwise the reduction units are supplied with the quantity of oil relating to position B3, (breather supplied).
- Only reduction units 110, 130 and 150 are fitted with breather, level and oil drainage plugs. It is necessary, after installation, to replace the closed plug used for transportation with the breather plug supplied with the unit.
- The pre-stage helical modules are supplied complete with life-long lubricant, synthetic oil and can therefore be mounted in all the positions. Lubrication is separated from that of the worm reduction unit.

Lubrication

In cases of ambient temperatures not envisaged in the table, call our Technical Service.

In the case of temperatures under -30°C or over 60°C it is necessary to use oil seals with special properties.

For operating ranges with temperatures under 0°C it is necessary to consider the following:

- 1- The motors need to be suitable for operation at the envisaged ambient temperature.

- 2- The power of the electric motor needs to be adequate for exceeding the higher starting torques required.
- 3- In the case of reduction units with a cast-iron case, pay attention to impact loads since cast iron may have problems of fragility at temperatures under -15°C.
- 4- During the early stages of service, problems of lubrication may arise due to the high level of viscosity taken on by the oil and so it is wise to have a few minutes of rotation under no load.

The oil needs to be changed after approximately 10,000 hours. This period depends on the type of service and the environment where the reduction unit works.

	T°C - ISO...	AGIP	SHELL	ESSO	MOBIL	CASTROL	BP
CMRV025-090 PC063-090 (synthetic oil)	-25) - (+50) ISO VG320	Telium VSF320	Tivela oil S320	S220	Glygoyle 30	Alphasyn PG32	Energol SG-XP320
CMRV110-150 (mineral oil)	-5) - (+40) ISO VG460	Blasia 460	Omala oil 460	Spartan EP460	Mobilgear 634	Alphamax 460	Energol GR-XP460
	-15) - (+25) ISO VG220	Blasia 220	Omala oil 220	Spartan EP220	Mobilgear 630	Alphamax 220	Energol GR-XP220

CMRV	025	030	040	050	063	075	090	110	130	150	PC	063	071	080	090
B3								3	4.5	7					
B8								2.2	3.3	5.1					
B6-B7	0.02	0.04	0.08	0.15	0.3	0.55	1	2.5	3.5	5.4		0.05	0.07	0.15	0.16
V5								3	4.5	7					
V6								2.2	3.3	5.1					

All dimensions in millimetres unless otherwise stated. Every effort has been taken to ensure that the data listed in this catalogue is correct. Challenge accepts no liability for any inaccuracies or damage caused.

Radial Loads

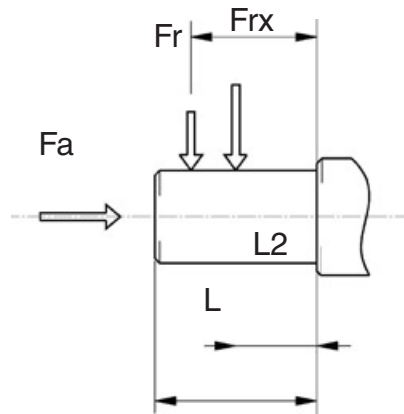

CRMV	025	030	040	050	063	075	090	110	130	150
a	50	65	84	101	120	131	162	176	188	215
b	38	50	64	76	95	101	122	136	148	174
Fr2 max	1350	1830	3490	4840	6270	7380	8180	12000	13500	18000

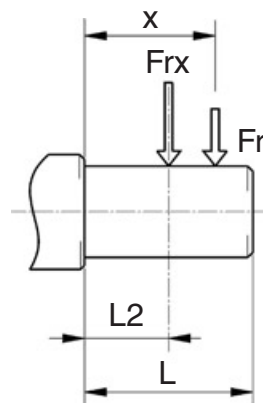

CRMV	030	040	050	063	075	090	110	130	150
a	86	106	129	159	192	227	266	314	350
b	76	94,5	114	139	176	202	236	274	310
Fr2 max	210	350	490	700	980	1270	1700	2100	2800

The radial load on the shaft is calculated with the following formula:

F_{re} (N) Resulting radial load

M (Nm) Torque on the shaft

D (mm) Diameter of the transmission member mounted on the shaft

F_r (N) Value of the maximum permitted radial load (see relative tables)

$f_z = 1.1$ gear pinion

1.4 chain wheel

1.7 v-pulley

2.5 flat pulley

When the resulting radial load is not applied on the centre line of the shaft it is necessary to calculate the effective load with the following formula:

$a, b, x =$ (see relative tables)

$$F_{re} = \frac{2000 \times M \times f_z}{D} \leq Fr1 \text{ to } Fr2$$

$$F_{re} \leq \frac{F_r \times a}{(b + x)} \leq Fr1max \text{ to } Fr2max$$

Possible Motor Flanges

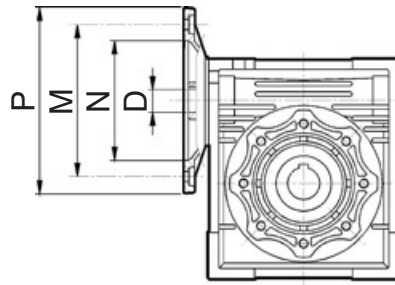

CMRV	PAM IEC	N	M	P	D											
					5	7,5	10	15	20	25	30	40	50	60	80	100
025	56B14	50	65	80	9	9	9	9	9	-	9	9	9	9	-	-
	63B5	95	115	140	11	11	11	11	11	11	11	11	11	-	-	
030	63B14	60	75	90												
	56B5	80	100	120	9	9	9	9	9	9	9	9	9	9	9	-
	56B14	50	65	80												
040	71B5	110	130	160	14	14	14	14	14	14	14	14	14	-	-	-
	71B14	70	85	105												
	63B5	95	115	140	11	11	11	11	11	11	11	11	11	11	11	11
	63B14	60	75	90												
050	56B5	80	100	120	-	-	-	-	-	-	-	-	9	9	9	9
	80B5	130	165	200	19	19	19	19	19	19	19	-	-	-	-	-
	80B14	80	100	120												
	71B5	110	130	160	14	14	14	14	14	14	14	14	14	14	14	-
	71B14	70	85	105												
063	63B5	95	115	140	-	-	-	-	-	-	-	11	11	11	11	11
	90B5	130	165	200	-	24	24	24	24	24	24	-	-	-	-	-
	90B14	95	115	140												
	80B5	130	165	200	-	19	19	19	19	19	19	19	19	19	-	-
	80B14	80	100	120												
	71B5	110	130	160	-	-	-	-	-	-	-	14	14	14	14	14
075	71B14	70	85	105												
	100/112B5	180	215	250	-	28	28	28	-	-	-	-	-	-	-	-
	100/112B14	110	130	160												
	90B5	130	165	200	-	24	24	24	24	24	24	24	-	-	-	-
	90B14	95	115	140												
	80B5	130	165	200	-	-	-	-	19	19	19	19	19	19	19	19
	80B14	80	100	120												
090	71B5	110	130	160	-	-	-	-	-	-	-	-	14	14	14	14
	100/112B5	180	215	250	-	28	28	28	28	28	28	-	-	-	-	-
	100/112B14	110	130	160												
	90B5	130	165	200	-	24	24	24	24	24	24	24	24	24	-	-
	90B14	95	115	140												
	80B5	130	165	200	-	-	-	-	-	-	-	19	19	19	19	19
110	80B14	80	100	120												
	132B5	230	265	300	-	38*	38*	38*	38*	-	-	-	-	-	-	-
	100/112B5	180	215	250	-	28	28	28	28	28	28	28	28	28	28	-
	90B5	130	165	200	-	-	-	-	-	24	24	24	24	24	24	24
130	80B5	130	165	200	-	-	-	-	-	-	-	-	-	-	19	19
	132B5	230	265	300	-	38*	38*	38*	38*	38*	38*	38*	-	-	-	-
	100/112B5	180	215	250	-	-	-	-	-	28	28	28	28	28	28	28
150	90B5	130	165	200	-	-	-	-	-	-	-	-	-	-	24	24
	160B5	250	300	350	-	42	42	42	42	42	-	-	-	-	-	-
	132B5	230	265	300	-	-	-	-	38	38	38	38	38	38	-	-
	100/112B5	180	215	250	-	-	-	-	-	-	-	-	28	28	28	28

* Low profile key supplied by Challenge

All dimensions in millimetres unless otherwise stated. Every effort has been taken to ensure that the data listed in this catalogue is correct. Challenge accepts no liability for any inaccuracies or damage caused.

PC & CMRV Combinations

.CMRV	i	PC 063		PC 071		PC 080			PC 090		
		105 / 11 i = 3	105 / 14 i = 3	120 / 14 i = 3	120 / 19 i = 3	160 / 19 i = 3	160 / 24 i = 3	160 / 28 i = 3	160 / 19 i = 2,42	160 / 24 i = 2,42	160 / 28 i = 2,42
040	25										
	30										
	40										
	50										
	60										
	80										
	100										
050	25										
	30										
	40										
	50										
	60										
	80										
	100										
063	25										
	30										
	40										
	50										
	60										
	80										
	100										
075	25										
	30										
	40										
	50										
	60										
	80										
	100										
090	25										
	30										
	40										
	50										
	60										
	80										
	100										
110	25										
	30										
	40										
	50										
	60										
	80										
	100										
130	25										
	30										
	40										
	50										
	60										
	80										
	100										

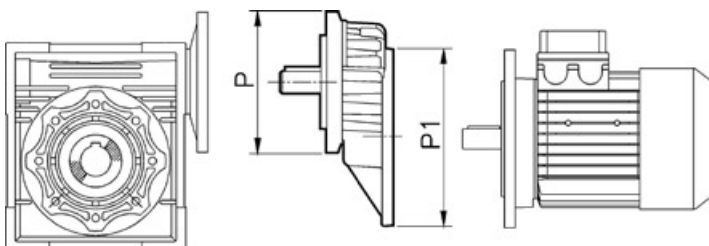

	P1	P	(P)
PC 063	63B5-140 /11		
PC 071	71B5-160 /14	120 / 14	(120 / 19)
PC 080	80B5-200 /19	160 / 14	(160 / 24) (160 / 28)
PC 090	90B5-200 /24	160 / 24	(160 / 19) (160 / 128)

(..) Only on request

Efficiency

Efficiency

Efficiency is a parameter which has a major influence on the sizing of certain applications, and basically depends on gear pair design elements.

The mesh data table on page 321 shows dynamic efficiency ($n_1=1400$ rev/min) and static efficiency values. Remember that these values are only achieved after the unit has been run in.

Dynamic Irreversibility

Dynamic irreversibility is achieved when the output shaft stops instantly when drive is no longer transmitted through the worm shaft. This condition requires a dynamic efficiency of $\eta_d < 0.5$.

Static Irreversibility

Static irreversibility is achieved when, with the gear reducer at a standstill, the application of a load to the output shaft does not set in motion the worm shaft. This condition requires a static efficiency of $\eta_s < 0.5$.

The table shows approximate irreversibility classes. Vibrations and shocks can affect a gear reducer's irreversibility. For the irreversibility conditions of a combined geared unit one must consider that the efficiency of the group is given by the product of the efficiencies of each single reducer, i.e.: $\eta_{tot} = \eta_1 \times \eta_2$

η_d	DYNAMIC IRREVERSIBILITY
> 0.6	Dynamic reversibility
0.5 to 0.6	Low dynamic reversibility
0.4 to 0.5	Good dynamic irreversibility
< 0.4	Dynamic irreversibility

η_s	STATIC IRREVERSIBILITY
> 0.55	Static reversibility
0.5 to 0.55	Low static reversibility
< 0.5	Static irreversibility

Mesh Data

RV	i=ratio	7.5	10	15	20	25	30	40	50	60	80	100
05	Z1	4	3	2	2		1	1	1	1		
	γ	25°03'	19°19'	13°09'	10°41'		6°40'	5°23'	4°31'	3°53'		
	Mx	1,3	1,3	1,3	0,995		1,3	0,995	0,8	0,67		
	$\eta_d(1400)$	0,85	0,83	0,79	0,75		0,67	0,62	0,58	0,55		
	η_s	0,71	0,68	0,61	0,56		0,46	0,41	0,36	0,34		
030	Z1	4	3	2	2	1	1	1	1	1	1	
	γ	18°49'	14°20'	9°40'	7°42'	5°35'	4°52'	3°52'	3°12'	2°45'	2°07'	
	Mx	1,44	1,44	1,44	1,09	1,7	1,44	1,09	0,89	0,74	0,56	
	$\eta_d(1400)$	0,85	0,82	0,77	0,73	0,68	0,65	0,59	0,55	0,51	0,44	
	η_s	0,67	0,63	0,55	0,5	0,43	0,39	0,35	0,31	0,27	0,23	
040	Z1	4	3	2	2	2	1	1	1	1	1	1
	γ	24°28'	18°51'	12°49'	10°23'	8°43'	6°29'	5°14'	4°23'	3°47'	2°57'	2°25'
	Mx	2,06	2,06	2,06	1,57	1,27	2,06	1,57	1,27	1,06	0,81	0,65
	$\eta_d(1400)$	0,87	0,85	0,82	0,78	0,75	0,7	0,65	0,62	0,58	0,52	0,47
	η_s	0,71	0,67	0,6	0,55	0,51	0,45	0,4	0,36	0,32	0,28	0,24
050	Z1	4	3	2	2	2	1	1	1	1	1	1
	γ	23°54'	18°23'	12°30'	10°06'	8°29'	6°19'	5°06'	4°16'	3°40'	2°52'	2°21'
	Mx	2,56	2,56	2,56	1,95	1,58	2,56	1,95	1,58	1,32	1	0,8
	$\eta_d(1400)$	0,88	0,86	0,82	0,79	0,76	0,72	0,67	0,63	0,59	0,53	0,49
	η_s	0,7	0,66	0,59	0,55	0,51	0,44	0,39	0,35	0,32	0,27	0,23
063	Z1	4	3	2	2	2	1	1	1	1	1	1
	γ	24°31'	18°53'	12°51'	10°25'	8°45'	6°30'	5°15'	4°24'	3°47'	2°58'	2°26'
	Mx	3,25	3,25	3,25	2,48	2	3,25	2,48	2	1,68	1,27	1,02
	$\eta_d(1400)$	0,88	0,87	0,83	0,81	0,78	0,74	0,7	0,66	0,62	0,57	0,51
	η_s	0,71	0,67	0,6	0,55	0,51	0,45	0,4	0,36	0,33	0,28	0,24
075	Z1	4	3	2	2	2	1	1	1	1	1	1
	γ	26°17'	20°20'	13°52'	11°18'	9°32'	7°02'	5°42'	4°48'	4°08'	3°14'	2°40'
	Mx	3,94	3,94	3,94	3	2,42	3,94	3	2,42	2,03	1,54	1,24
	$\eta_d(1400)$	0,89	0,88	0,85	0,82	0,80	0,76	0,72	0,69	0,65	0,60	0,55
	η_s	0,71	0,68	0,61	0,57	0,53	0,46	0,42	0,38	0,35	0,29	0,26
090	Z1	4	3	2	2	2	1	1	1	1	1	1
	γ	29°11'	22°44'	15°36'	12°50'	10°54'	7°57'	6°30'	5°30'	4°46'	3°45'	3°06'
	Mx	4,84	4,84	4,84	3,69	2,98	4,84	3,69	2,98	2,5	1,89	1,52
	$\eta_d(1400)$	0,9	0,89	0,86	0,84	0,82	0,78	0,75	0,72	0,69	0,63	0,59
	η_s	0,73	0,7	0,64	0,6	0,56	0,49	0,45	0,41	0,38	0,32	0,28
110	Z1	4	3	2	2	2	1	1	1	1	1	1
	γ	28°15'	21°57'	15°02'	14°41'	12°34'	7°39'	7°28'	6°22'	5°32'	4°24'	3°39'
	Mx	5,875	5,875	5,875	4,62	3,73	5,875	4,62	3,73	3,13	2,37	1,91
	$\eta_d(1400)$	0,9	0,89	0,86	0,85	0,84	0,79	0,78	0,75	0,72	0,67	0,63
	η_s	0,72	0,69	0,63	0,62	0,59	0,48	0,48	0,44	0,41	0,36	0,32
130	Z1	4	3	2	2	2	1	1	1	1	1	1
	γ	28°41'	22°19'	15°18'	13°52'	11°49'	7°47'	7°02'	5°58'	5°11'	4°07'	3°24'
	Mx	6,97	6,97	6,97	5,4	4,37	6,97	5,4	4,37	3,67	2,77	2,23
	$\eta_d(1400)$	0,91	0,89	0,87	0,86	0,84	0,8	0,78	0,75	0,72	0,68	0,64
	η_s	0,72	0,69	0,63	0,61	0,58	0,49	0,46	0,43	0,39	0,34	0,3
150	Z1	6	4	3	2	2	2	1	1	1	1	1
	γ	32°09'	24°35'	17°27'	12°53'	11°19'	9°50'	6°32'	5°43'	4°57'	3°55'	3°14'
	Mx	5,5	6,155	5,5	6,155	5	4,193	6,155	5	4,193	3,17	2,55
	$\eta_d(1400)$	0,91	0,9	0,88	0,86	0,84	0,83	0,78	0,76	0,73	0,68	0,64
	η_s	0,73	0,71	0,66	0,6	0,57	0,54	0,45	0,42	0,39	0,33	0,29

Materials and Design Features (PC)

The PC construction is modular and therefore it can be supplied as a separate unit to be mounted on any type of fitted geared motor (PAM). In this connection, the various possibilities of flange/output shafts.

Fitting the pre-stage helical module on the main reduction unit is easily done as for any motor of type B14.

The pre-stage unit cannot be used by itself, but only coupled with another reduction unit.

Materials

Case in aluminium alloy.

Gears in case hardened, hardened, tempered steel 20MnCr5 (UNI7846) accurately ground on the involute.

Coupling to electric motor

Correctly fitting the pinion on the electric motor shaft requires you keep to the following instructions:

- a) Thoroughly clean the electric motor shaft.
- b) Remove the motor key from its seat.
- c) Fit the bush (1) to the drive shaft as shown in the diagram. To make this easier, you can heat the bush to approximately 70/80°C.
- d) Fit the new key (3) provided in place of the one removed beforehand.
- e) Fit the pinion (4) taking the same precautions as described in point (c).
- f) Fit the washer (5) and tighten with the screw (6).
- g) Remove the rubber cap mounted on the seat of the oil seal, taking care since the pre-stage unit is already complete with lubricant.
- h) Fit the oil seal (2) and then the motor assembly, taking care not to damage the lip of the oil seal.

N.B. For correct operation, with no vibration or noise, it is recommended to use good quality motors.

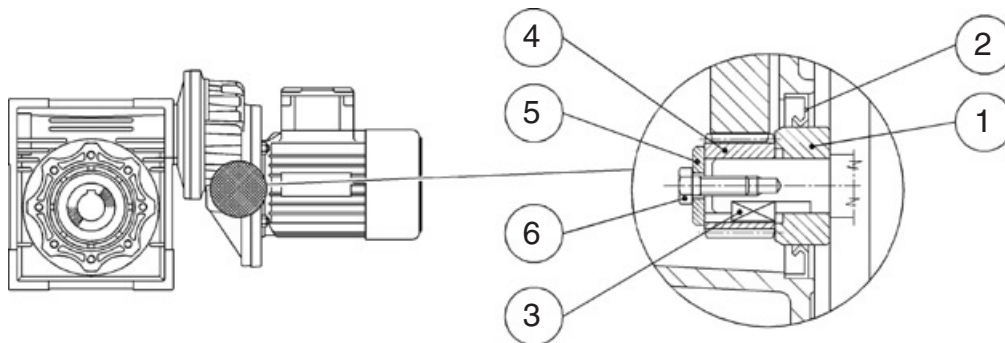

Mounting Positions

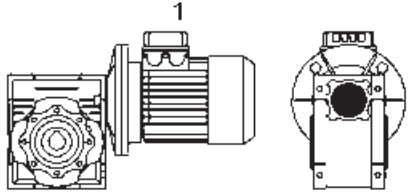
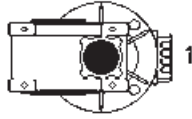
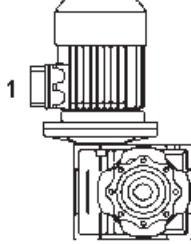
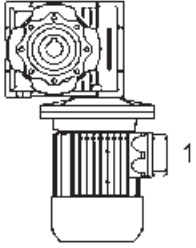
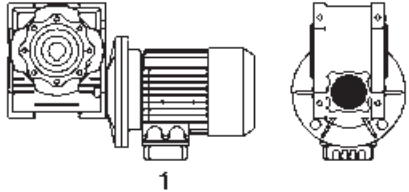
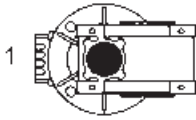
CMRV - CRV			
CMRV...U - B3	B6	V5	V6
			
B8	B7		
			

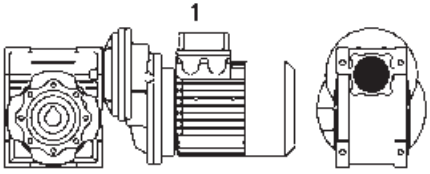
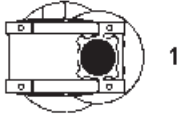
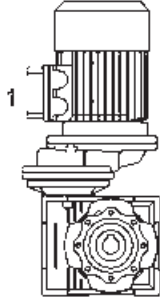
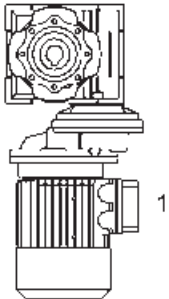
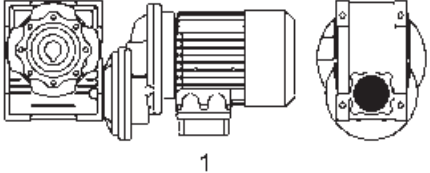
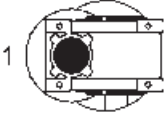
PC - CMRV			
CMRV...U - B3	B6	V5	V6
			
B8	B7		
			

“U” version is related to sizes from CMRV 025-075 and CRV 030-063. For these sizes it is not necessary to specify mounting position.

Unless specified otherwise, the standard positions are B3.

For positions not envisaged, it is necessary to email our Technical Service.

technicalsupport@challengeproduction.com

Execution of Double Reduction

CMRV-CMRV / CRV-CMRV			
AS1	AS2	VS1	VS2
PS1	PS2	BS1	BS2

The position of the 1st reducer with respect to the 2nd gear reducer depend on the version. Unless otherwise specified at the time of order, combination groups are supplied in version BS2. The specified mounting position refers to the 2nd gear reducer.

Flange F	
D	S

Unless specified otherwise, the reduction unit is supplied with the flange in pos. D referred to position B3.

In the case of specific requirements, when ordering, specify the position of the terminal box as shown in the diagram.



CMRV Performance

input n1 = 1400 rev/min		Geared Motors					Gear Units			
i	output n2 = rev/min	Size	P1 (kW)	Motor Frame	M2 (Nm)	f.s.	Size	M2 (Nm)	Fr1 (N)	Fr2 (N)
7.5	186.7	CMRV025	0.09	56B4	3.9	2.8	CRV025	10	118	503
10	140.0		0.09	56B4	5.1	2.4		10	118	553
15	93.3		0.09	56B4	7.3	1.6		11	118	633
20	70.0		0.09	56B4	9.0	1.3		11	118	697
30	46.7		0.09	56B4	12	1.1		12	118	798
40	35.0		0.09	56B4	15	0.9		12	118	878
50	28.0		0.06	56A4	12	0.9		10	118	946
60	23.3		0.06	56A4	14	0.7		10	118	1006
7.5	186.7	CMRV030	0.22	63C4	10	1.9	CRV030	18	150	683
10	140.0		0.22	63C4	12	1.5		18	169	752
15	93.3		0.22	63C4	17	1.0		18	169	861
20	70.0		0.22	63C4	22	0.8		18	190	948
25	56.0		0.18	63B4	21	1.0		21	210	1021
30	46.7		0.18	63B4	24	0.8		20	210	1085
40	35.0		0.12	63A4	19	0.9		18	210	1194
50	28.0		0.12	63A4	23	0.8		17	210	1286
60	23.3		0.09	56B4	19	0.9		16	210	1367
80	17.5		0.06	56A4	14	0.9		13	210	1504
7.5	186.7	CMRV040	0.55	71C4	24	1.6	CRV040	40	294	1315
10	140.0		0.55	71C4	32	1.3		40	331	1447
15	93.3		0.55	71C4	46	0.9		40	331	1657
20	70.0		0.37	71B4	39	1.0		39	350	1824
25	56.0		0.37	71B4	47	0.8		38	350	1964
30	46.7		0.37	71B4	53	0.8		45	350	2087
40	35.0		0.25	71A4	44	0.9		41	350	2298
50	28.0		0.22	63C4	47	0.8		39	350	2475
60	23.3		0.18	63B4	43	0.8		36	350	2630
80	17.5		0.12	63A4	34	1.0		33	350	2895
100	14.0	0.12	63A4	38	0.8	29	350	3118		
7.5	186.7	CMRV050	0.92	80C4	41	1.7	CRV050	71	401	1805
10	140.0		0.92	80C4	54	1.3		72	490	1987
15	93.3		0.92	80C4	77	1.0		74	490	2274
20	70.0		0.75	80B4	81	0.9		73	490	2503
25	56.0		0.55	80A4	71	1.0		70	490	2696
30	46.7		0.55	80A4	81	1.0		84	490	2865
40	35.0		0.37	71B4	68	1.1		76	490	3153
50	28.0		0.37	71B4	80	0.9		73	490	3397
60	23.3		0.37	71B4	89	0.8		68	490	3610
80	17.5		0.25	71A4	72	0.9		65	490	3973
100	14.0	0.18	63B4	60	0.9	55	490	4280		

CMRV Performance

input n1 = 1400 rev/min		Geared Motors					Gear Units			
i	output n2 = rev/min	Size	P1 (kW)	Motor Frame	M2 (Nm)	f.s.	Size	M2 (Nm)	Fr1 (N)	Fr2 (N)
7.5	186.7	CMRV063	1.84	90LL4	83	1.5	CRV063	128	500	2359
10	140.0		1.84	90LL4	109	1.2		130	571	2597
15	93.3		1.84	90LL4	156	0.9		140	615	2973
20	70.0		1.5	90LL4	166	0.8		135	667	3272
25	56.0		1.1	90S4	146	0.9		130	700	3524
30	46.7		1.1	90S4	167	1.0		160	700	3745
40	35.0		0.92	80C4	176	0.8		145	700	4122
50	28.0		0.55	80A4	124	1.1		135	700	4440
60	23.3		0.55	80A4	140	0.9		130	700	4719
80	17.5		0.37	71B4	115	1.1		122	700	5193
100	14.0		0.37	71B4	129	0.9		118	700	5595
7.5	186.7	CMRV075	4	112M4	182	1.0	CRV075	185	700	2785
10	140.0		4	112M4	240	0.8		195	830	3065
15	93.3		3	100L4	261	0.8		200	851	3509
20	70.0		1.84	90LL4	206	1.0		210	980	3862
25	56.0		1.84	90LL4	251	0.8		200	980	4160
30	46.7		1.84	90LL4	286	0.8		230	980	4421
40	35.0		1.1	90S4	216	1.0		220	980	4865
50	28.0		0.92	80C4	217	1.0		210	980	5241
60	23.3		0.92	80C4	245	0.8		200	980	5569
80	17.5		0.55	80A4	180	1.1		190	980	6130
100	14.0		0.55	80A4	206	0.9		180	980	6603
7.5	186.7	CMRV090	4.8	112MS4	221	1.3	CRV090	290	900	3081
10	140.0		4.8	112MS4	291	1.1		310	1082	3391
15	93.3		4.8	112MS4	422	0.9		360	1257	3882
20	70.0		4	112M4	458	0.8		355	1270	4273
25	56.0		3	100LB4	420	0.8		340	1270	4603
30	46.7		3	100LB4	479	0.9		410	1270	4891
40	35.0		1.84	90LL4	377	1.0		360	1270	5383
50	28.0		1.84	90LL4	452	0.8		340	1270	5799
60	23.3		1.5	90LL4	424	0.8		320	1270	6163
80	17.5		0.92	80C4	316	0.9		285	1270	6783
100	14.0		0.75	80B4	302	0.9		270	1270	7306

All dimensions in millimetres unless otherwise stated. Every effort has been taken to ensure that the data listed in this catalogue is correct. Challenge accepts no liability for any inaccuracies or damage caused.

CMRV Performance

input n1 = 1400 rev/min		Geared Motors					Gear Units			
i	output n2 = rev/min	Size	P1 (kW)	Motor Frame	M2 (Nm)	f.s.	Size	M2 (Nm)	Fr1 (N)	Fr2 (N)
7.5	186.7	CMRV110	9.2	132M4	424	1.3	CRV110	552	1200	3893
10	140.0		7.5	132L4	455	1.3		598	1463	4285
15	93.3		7.5	132L4	660	1.0		656	1604	4905
20	70.0		5.5	132S4	638	1.0		644	1700	5399
25	56.0		4.8	112MS4	688	1.0		679	1700	5816
30	46.7		4	112M4	647	1.1		725	1700	6181
40	35.0		3	100LB4	638	1.1		702	1700	6803
50	28.0		3	100LB4	767	0.9		660	1700	7328
60	23.3		2.2	100LA4	648	1.0		616	1700	7787
80	17.5		1.5	90L4	548	0.9		515	1700	8571
100	14.0	1.1	90S4	473	1.0	483	1700	9232		
7.5	186.7	CMRV130	9.2	132M4	428	1.8	CRV130	750	1500	5092
10	140.0		9.2	132M4	559	1.5		820	1845	5605
15	93.3		9.2	132M4	819	1.1		920	2070	6416
20	70.0		9.2	132M4	1079	0.8		910	2100	7062
25	56.0		9.2	132M4	1318	0.7		930	2100	7607
30	46.7		7.5	132L4	1228	0.8		1040	2100	8084
40	35.0		7.5	132L4	1596	0.7		1050	2100	8897
50	28.0		4.8	112MS4	1228	0.8		980	2100	9584
60	23.3		4	112M4	1179	0.8		900	2100	10185
80	17.5		3	100LB4	1113	0.8		840	2100	11210
100	14.0	1.84	90LL4	803	0.9	740	2100	12076		
7.5	186.7	CMRV150	15	160L4	698	1.7	CRV150	1200	1950	6962
10	140.0		15	160L4	921	1.3		1240	2267	7663
15	93.3		15	160L4	1351	0.9		1250	2285	8771
20	70.0		15	160L4	1760	0.7		1300	2674	9654
25	56.0		11	160M4	1576	0.8		1200	2800	10400
30	46.7		9.2	132M4	1563	0.8		1200	2800	11051
40	35.0		9.2	132M4	1958	0.8		1550	2800	12163
50	28.0		5.5	132S4	1426	1.0		1400	2800	13103
60	23.3		5.5	132S4	1643	0.8		1260	2800	13924
80	17.5		4	112M4	1484	0.8		1150	2800	15325
100	14.0	3	100LB4	1310	0.8	1000	2800	16508		

PC-CMRV Performance

input n1 = 1400 rev/min		Geared Motors					
i	output n2 = rev/min	Size	P1 (kW)	Motor Frame	M2 (Nm)	f.s.	Fr2 (N)
75	18.7	PC063+CMRV040	0.18	63B4	64	0.8	2833
90	15.6		0.18	63B4	70	0.8	3011
120	11.7		0.18	63B4	85	0.6	3314
150	9.3		0.12	63A4	66	0.7	3490
180	7.8		0.12	63A4	74	0.6	3490
240	5.8		0.12	63A4	86	0.5	3490
75	18.7	PC063+CMRV050	0.22	63C4	78	1.2	3889
90	15.6		0.22	63C4	86	1.2	4132
120	11.7		0.22	63C4	106	0.9	4548
150	9.3		0.18	63B4	101	0.9	4840
180	7.8		0.18	63B4	113	0.7	4840
240	5.8		0.18	63B4	133	0.6	4840
300	4.7		0.12	63A4	98	0.7	4840
120	11.7	PC063+CMRV063	0.22	63C4	110	1.7	5945
150	9.3		0.22	63C4	126	1.4	6270
180	7.8		0.22	63C4	143	1.1	6270
240	5.8		0.18	63B4	139	1.0	6270
300	4.7		0.18	63B4	155	0.8	6270
75	18.7	PC071+CMRV050	0.25	71A4	88	1.0	3889
90	15.6		0.25	71A4	98	1.1	4132
120	11.7		0.25	71A4	121	0.8	4548
150	9.3		0.25	71A4	141	0.6	4840
75	18.7	PC071+CMRV063	0.25	71A4	91	1.8	5083
90	15.6		0.55	71C4	219	0.9	5401
120	11.7		0.37	71B4	185	1.0	5945
150	9.3		0.37	71B4	212	0.8	6270
180	7.8		0.25	71A4	163	1.0	6270
240	5.8		0.25	71A4	192	0.7	6270
300	4.7		0.25	71A4	215	0.6	6270
75	18.7	PC071+CMRV075	0.55	71C4	205	1.2	6000
90	15.6		0.55	71C4	230	1.3	6375
120	11.7		0.55	71C4	284	1.0	7017
150	9.3		0.37	71B4	223	1.1	7380
180	7.8		0.37	71B4	254	0.9	7380
240	5.8		0.25	71A4	201	1.1	7380
300	4.7		0.25	71A4	230	0.9	7380
120	11.7		PC071+CMRV090	0.55	71C4	297	1.6
150	9.3	0.55		71C4	355	1.3	8180
180	7.8	0.55		71C4	398	1.0	8180
240	5.8	0.37		71B4	321	1.1	8180
300	4.7	0.37		71B4	371	0.9	8180

All dimensions in millimetres unless otherwise stated. Every effort has been taken to ensure that the data listed in this catalogue is correct. Challenge accepts no liability for any inaccuracies or damage caused.

PC-CMRV Performance

input n1 = 1400 rev/min		Geared Motors					
i	output n2 = rev/min	Size	P1 (kW)	Motor Frame	M2 (Nm)	f.s.	Fr2 (N)
75	18.7	PC080+CMRV075	0.92	80C4	344	0.7	6000
90	15.6		0.92	80C4	384	0.8	6375
120	11.7		0.55	80A4	284	1.0	7017
150	9.3		0.55	80A4	332	0.8	7380
180	7.8		0.55	80A4	378	0.6	7380
75	18.7	PC080+CMRV090	0.92	80C4	353	1.2	6638
90	15.6		0.92	80C4	401	1.4	7054
120	11.7		0.92	80C4	497	1.0	7764
150	9.3		0.92	80C4	593	0.8	8180
180	7.8		0.75	80B4	543	0.7	8180
75	18.7	PC080+CMRV110	0.92	80C4	367	2.5	8388
120	11.7		0.92	80C4	527	1.8	9811
150	9.3		0.92	80C4	621	1.4	10320
180	7.8		0.92	80C4	712	1.1	10320
240	5.8		0.75	80B4	700	0.9	10320
300	4.7		0.55	80A4	597	1.0	10320
75	18.7		PC080+CMRV130	0.92	80C4	367	3.3
90	15.6	0.92		80C4	412	3.4	11659
120	11.7	0.92		80C4	527	2.5	12832
150	9.3	0.92		80C4	631	1.9	13500
180	7.8	0.92		80C4	712	1.5	13500
240	5.8	0.92		80C4	874	1.1	13500
300	4.7	0.92		80C4	998	0.9	13500
60.5	23.1	PC090+CMRV110		1.84	90LL4	592	1.5
72.6	19.3		1.84	90LL4	656	1.5	8298
97	14.5		1.84	90LL4	850	1.1	9133
121.0	11.6		1.84	90LL4	1002	0.9	9838
145	9.6		1.5	90L4	936	0.8	10320
193.6	7.2		1.1	90S4	828	0.8	10320
242.0	5.8		1.1	90S4	962	0.6	10320
60.5	23.1	PC090+CMRV130	1.84	90LL4	592	2.0	10213
72.6	19.3		1.84	90LL4	665	2.1	10853
97	14.5		1.84	90LL4	850	1.5	11945
121.0	11.6		1.84	90LL4	1018	1.2	12868
145.2	9.6		1.84	90LL4	1148	0.9	13500
193.6	7.2		1.5	90L4	1149	0.8	13500
242	5.8		1.1	90S4	962	0.9	13500

CMRV-CMRV Performance

input n1 = 1400 rev/min		Geared Motors					Gear Units							
i	output n2 = rev/min	Size	P1 (kW)	Motor Frame	M2 (Nm)	f.s.	Size	M2 (Nm)	Fr1 (N)	Fr2 (N)				
100	14.0	CMRV025/030	0.09	56B4	38	0.8				1620				
150	9.3		0.09	56B4	49	0.6				1830				
200	7.0		0.09	56B4	62	0.5				1830				
250	5.6		0.09	56B4	66	0.5				1830				
300	4.7		0.09	56B4	75	0.4				1830				
400	3.5		0.09	56B4	107	0.3				1830				
500	2.8		0.09	56B4	115	0.3				1830				
600	2.3		0.09	56B4	135	0.2				1830				
750	1.9		0.09	56B4	151	0.2				1830				
900	1.6		0.09	56B4	178	0.2				1830				
1200	1.2		0.09	56B4	212	0.1				1830				
1500	0.9		0.09	56B4	247	0.1				1830				
1800	0.78		0.09	56B4	304	0.1				1830				
2400	0.58		0.09	56B4	340	0.1				1830				
3000	0.47		0.09	56B4	405	0.1				1830				
300	4.7	CMRV025/040	0.06	56A4	59	1.2				3490				
400	3.5		0.06	56A4	71	0.9				3490				
500	2.8		0.06	56A4	82	0.7				3490				
600	2.3		0.06	56A4	101	0.6				3490				
750	1.9		0.06	56A4	116	0.5				3490				
900	1.6		0.06	56A4	143	0.5				3490				
1200	1.2		0.06	56A4	171	0.4				3490				
1500	0.9		0.06	56A4	197	0.3				3490				
1800	0.8		0.06	56A4	217	0.3				3490				
2400	0.6		0.06	56A4	268	0.2				3490				
3000	0.5		0.06	56A4	324	0.2				3490				
4000	0.4		0.06	56A4	294	0.1				3490				
5000	0.3		0.06	56A4	356	0.1				3490				
300	4.7		CMRV030/040	0.09	56B4	88				0.8	CRV030/040	73	210	3490
400	3.5			0.06	56A4	70				0.9		65	210	3490
500	2.8	0.06		56A4	96	0.6	61	210	3490					
600	2.3	0.06		56A4	104	0.7	73	210	3490					
750	1.9	0.06		56A4	121	0.6	73	210	3490					
900	1.6	0.06		56A4	139	0.5	73	210	3490					
1200	1.2	0.06		56A4	166	0.4	65	210	3490					
1500	0.9	0.06		56A4	196	0.4	73	210	3490					
1800	0.8	0.06		56A4	218	0.3	73	210	3490					
2400	0.58	0.06		56A4	261	0.2	65	210	3490					
3200	0.4	0.06		56A4	300	0.2	65	210	3490					
4000	0.4	0.06		56A4	279	0.1	33	210	3490					
5000	0.28	0.06		56A4	338	0.1	29	210	3490					

All dimensions in millimetres unless otherwise stated. Every effort has been taken to ensure that the data listed in this catalogue is correct. Challenge accepts no liability for any inaccuracies or damage caused.

CMRV-CMRV Performance

input n1 = 1400 rev/min		Geared Motors					Gear Units			
i	output n2 = rev/min	Size	P1 (kW)	Motor Frame	M2 (Nm)	f.s.	Size	M2 (Nm)	Fr1 (N)	Fr2 (N)
300	4.7	CMRV030/050	0.12	63A4	119	1.2	CRV030/050	145	210	4840
400	3.5		0.12	63A4	142	0.9		124	210	4840
500	2.8		0.12	63A4	164	0.7		120	210	4840
600	2.3		0.09	56B4	159	0.9		145	210	4840
750	1.9		0.09	56B4	185	0.8		145	210	4840
900	1.6		0.09	56B4	212	0.7		145	210	4840
1200	1.2		0.06	56A4	169	0.7		124	210	4840
1500	0.93		0.06	56A4	199	0.7		145	210	4840
1800	0.78		0.06	56A4	222	0.7		145	210	4840
2400	0.6		0.06	56A4	266	0.5		124	210	4840
3000	0.5		0.06	56A4	307	0.4		120	210	4840
4000	0.35		0.06	56A4	288	0.3		82	210	4840
4800	0.29		0.06	56A4	311	0.3		82	210	4840
300	4.7		CMRV030/063	0.22	63C4	210		1.1	CRV030/063	230
400	3.5	0.22		63C4	271	0.8	230	210		6270
500	2.8	0.18		63B4	257	0.8	216	210		6270
600	2.3	0.12		63A4	208	1.1	230	210		6270
750	1.9	0.12		63A4	241	0.9	216	210		6270
900	1.6	0.09		56B4	200	1.0	198	210		6270
1200	1.2	0.09		56B4	263	0.9	230	210		6270
1500	0.93	0.09		56B4	305	0.7	216	210		6270
1800	0.78	0.06		56A4	225	0.9	198	210		6270
2400	0.58	0.06		56A4	276	0.8	230	210		6270
3000	0.47	0.06		56A4	319	0.7	216	210		6270
4000	0.35	0.06		56A4	306	0.6	172	210		6270
5000	0.28	0.06		56A4	360	0.4	150	210		6270
300	4.7	CMRV040/075		0.37	71B4	405	1.0	CRV040/075		390
400	3.5		0.37	71B4	498	0.7	360		350	7380
500	2.8		0.25	71A4	384	0.8	320		350	7380
600	2.3		0.18	63B4	362	1.1	390		350	7380
750	1.9		0.18	63B4	435	0.9	390		350	7380
900	1.6		0.18	63B4	487	0.8	390		350	7380
1200	1.2		0.12	63A4	399	0.9	360		350	7380
1500	0.93		0.09	56B4	360	1.1	390		350	7380
1800	0.78		0.09	56B4	404	1.0	390		350	7380
2400	0.58		0.09	56B4	496	0.7	360		350	7380
3000	0.47		0.06	56A4	377	0.8	320		350	7380
4000	0.35		0.06	56A4	355	0.7	250		350	7380
5000	0.28		0.06	56A4	419	0.5	230		350	7380

CMRV-CMRV Performance

input n1 = 1400 rev/min		Geared Motors					Gear Units			
i	output n2 = rev/min	Size	P1 (kW)	Motor Frame	M2 (Nm)	f.s.	Size	M2 (Nm)	Fr1 (N)	Fr2 (N)
300	4.7	CMRV040/090	0.37	71B4	402	1.5	CRV040/090	610	350	8180
400	3.5		0.37	71B4	523	1.2		610	350	8180
500	2.8		0.37	71B4	611	0.9		560	350	8180
600	2.3		0.37	71B4	757	0.8		610	350	8180
750	1.9		0.25	71A4	598	0.9		560	350	8180
900	1.6		0.25	71A4	667	0.8		505	350	8180
1200	1.2		0.18	63B4	629	1.0		610	350	8180
1500	0.93		0.18	63B4	735	0.8		560	350	8180
1800	0.78		0.12	63A4	547	0.9		505	350	8180
2400	0.58		0.12	63A4	695	0.9		610	350	8180
3000	0.47		0.09	56B4	609	0.9		560	350	8180
4000	0.35		0.09	56B4	548	0.8		460	350	8180
5000	0.28		0.06	56A4	431	1.0		410	350	8180
300	4.7		CMRV050/110	0.92	80C4	1069		1.2	CRV050/110	1265
400	3.5	0.92		80C4	1382	0.9	1185	490		10320
500	2.8	0.55		80A4	984	1.1	1100	490		10320
600	2.3	0.55		80A4	1181	1.0	1185	490		10320
750	1.9	0.55		80A4	1411	0.9	1265	490		10320
900	1.6	0.37		71B4	1079	1.2	1265	490		10320
1200	1.2	0.37		71B4	1396	0.8	1185	490		10320
1500	0.93	0.25		71A4	1064	1.2	1265	490		10320
1800	0.78	0.25		71A4	1195	1.1	1265	490		10320
2400	0.58	0.18		63B4	1113	1.1	1185	490		10320
3000	0.47	0.12		63A4	884	1.2	1100	490		10320
4000	0.35	0.12		63A4	784	1.0	819	490		10320
5000	0.28	0.12		63A4	928	0.80	746	490		10320
300	4.7	CMRV063/130		1.5	90L4	1789	1.0	CRV063/130		1760
400	3.5		1.5	90L4	2279	0.7	1650		700	13500
500	2.8		1.1	90S4	1991	0.8	1550		700	13500
600	2.3		0.75	80B4	1631	1.0	1650		700	13500
750	1.9		0.75	80B4	2005	0.9	1760		700	13500
900	1.6		0.75	80B4	2283	0.8	1760		700	13500
1200	1.2		0.55	80A4	2132	0.8	1650		700	13500
1500	0.93		0.37	71B4	1674	1.1	1760		700	13500
1800	0.78		0.37	71B4	1887	0.9	1760		700	13500
2400	0.58		0.25	71A4	1624	1.0	1650		700	13500
3000	0.47		0.25	71A4	1935	0.8	1550		700	13500
4000	0.35		0.25	71A4	2046	0.6	1220		700	13500
5000	0.28		0.25	71A4	2430	0.5	1100		700	13500

All dimensions in millimetres unless otherwise stated. Every effort has been taken to ensure that the data listed in this catalogue is correct. Challenge accepts no liability for any inaccuracies or damage caused.

CMRV-CMRV Performance

input n1 = 1400 rev/min		Geared Motors					Gear Units			
i	output n2 = rev/min	Size	P1 (kW)	Motor Frame	M2 (Nm)	f.s.	Size	M2 (Nm)	Fr1 (N)	Fr2 (N)
150	9.3	CRV063/150	1.84	90LL4	1259	1.9	CRV063/150	2340	700	18000
200	7.0		1.84	90LL4	1616	1.4		2340	700	18000
250	5.6		1.84	90LL4	1966	1.0		2050	700	18000
300	4.7		1.84	90LL4	2281	1.0		2340	700	18000
400	3.5		1.84	90LL4	2708	1.0		2670	700	18000
500	2.8		1.84	90LL4	3167	0.7		2330	700	18000
600	2.3		1.5	90L4	3057	0.9		2670	700	18000
750	1.9		1.1	90S4	2616	0.9		2330	700	18000
900	1.6		0.92	80C4	2717	0.8		2100	700	18000
1200	1.2		0.92	80C4	3288	0.8		2670	700	18000
1800	0.8		0.55	80A4	2638	0.8		2100	700	18000
2400	0.6		0.55	80A4	3182	0.8		2670	700	18000
3000	0.5		0.37	71B4	2535	0.9		2330	700	18000
4000	0.4		0.25	71A4	2026	0.9		1880	700	18000
5000	0.3		0.25	71A4	2251	0.7		1650	700	18000

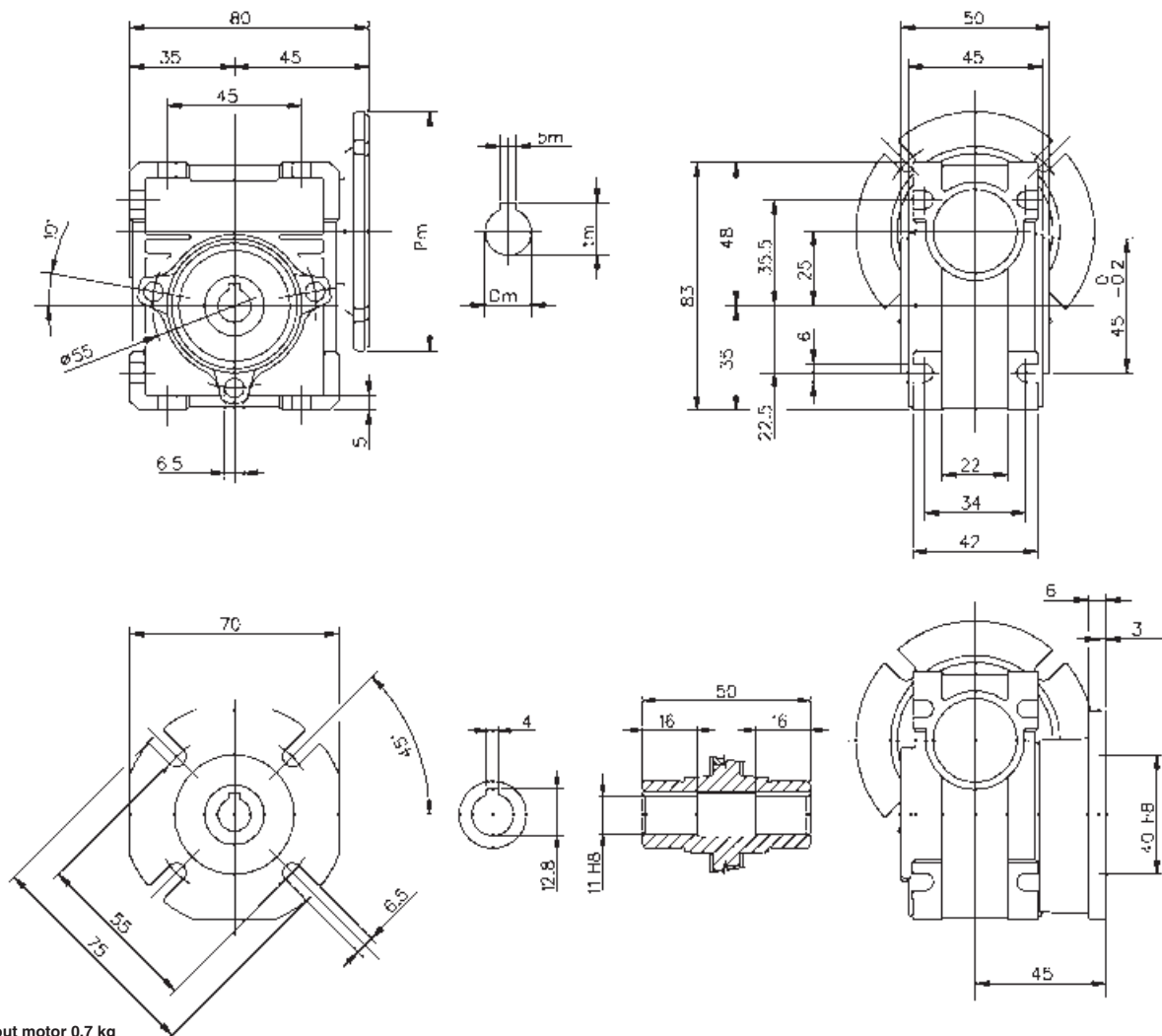

Weight without motor 0.7 kg

For the dimensions concerning the motor connection area (Pm, Dm, bm, tm) please refer to the table shown at page 28.

Every effort has been taken to ensure that the data listed in this catalogue is correct. Challenge accepts no liability for any inaccuracies or damage caused. All dimensions in millimetres unless otherwise stated.

Dimensions

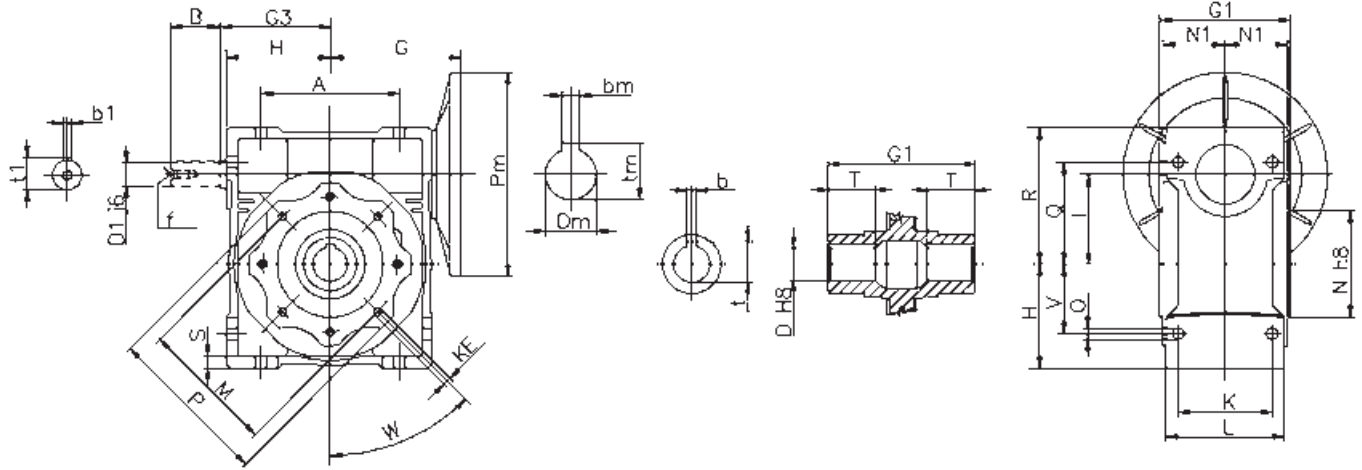

	030	040	050	063	075	090	110	130	150
A	54	70	80	100	120	140	170	200	240
B	20	23	30	40	50	50	60	80	80
D	14	18	25	25	28	35	42	45	50
D1	9	11	14	19	24	24	28	30	35
G	55	70	80	95	112.5	129.5	160	180	210
G1	63	78	92	112	120	140	155	170	200
G3	45	53	64	75	90	108	135	155	175
H	40	50	60	72	86	103	127.5	147.5	170
I	30	40	50	63	75	90	110	130	150
K	44	60	70	85	90	100	115	120	145
KE	M6*11 (4)	M6*10 (4)	M8*10 (4)	M8*14(8)	M8*14(8)	M10*18(8)	M10*18(8)	M12*21(8)	M12*21(8)
L	56	71	85	103	112	130	144	155	185
M	65	75	85	95	115	130	165	215	215
N	55	60	70	80	95	110	130	180	180
N1	29	36.5	43.5	53	57	67	74	81	96
O	6.5	6.5	8.5	8.5	11.5	13	14	16	18
P	75	87	100	110	140	160	200	250	250
Q	44	55	64	80	93	102	125	140	180
R	57	71.5	84	102	119	135	167.5	187.5	230
S	5.5	6.5	7	8	10	11	14.5	15.5	18
T	21	26	30	36	40	45	50	60	72.5
V	27	35	40	50	60	70	85	100	120
W	45°	45°	45°	45°	45°	45°	45°	45°	45°
b	5	6	8	8	8 (10)	10	12	14	14
t	16.3	20.8 (21.8)	28.3 (27.3)	28.3 (31.3)	31.3 (38.3)	38.3 (41.3)	45.3	48.8	53.8
b1	3	4	5	6	8	8	8	8	10
t1	10.2	12.5	16	21.5	27	27	31	33	38
f	-	-	M6	M6	M8	M8	M10	M10	M12
kg	1.2	2.3	3.5	6.2	9	13	35	48	84

kg = Weight without motor

For the dimensions concerning the motor connection area (Pm, Dm, bm, tm) please refer to the table shown at page 28.

All dimensions in millimetres unless otherwise stated. Every effort has been taken to ensure that the data listed in this catalogue is correct. Challenge accepts no liability for any inaccuracies or damage caused.

Dimensions of Output Flanges

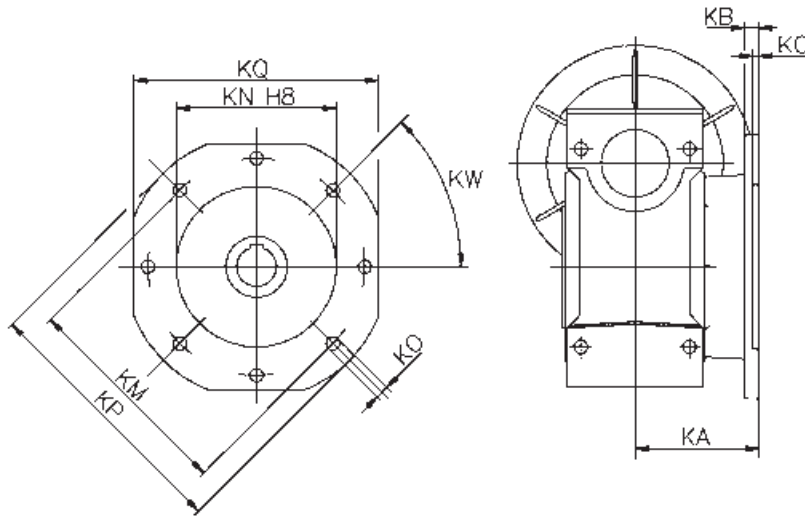

Flange	030	040	050	063	075	090	110	130	150	
F	KA	54.5	67	90	82	111	111	131	140	155
	KB	6	7	9	10	13	13	15	15	15
	KC	4	4	5	6	6	6	6	6	6
	KN	50	60	70	115	130	152	170	180	180
	KM	68	80 min	90 min	150	165	175	230	255	255
	KO	6.5 x 4	9 x 4	11 x 4	11 x 4	14 x 4	14 x 4	14 x 8	16 x 8	16 x 8
	KP	80	110	125	180	200	210	280	320	320
	KQ	70	95	110	142	170	200	260	290	290
	KW	45°	45°	45°	45°	45°	45°	45°	22.5°	22.5°
FL	KA	-	97	120	112	90	122	180	-	-
	KB	-	7	9	10	13	18	15	-	-
	KC	-	4	5	6	6	6	6	-	-
	KN	-	60	70	115	110	180	170	-	-
	KM	-	80 min	90 min	150	130	215	230	-	-
	KO	-	9 x 4	11 x 4	11 x 4	14 x 4	14 x 4	14 x 8	-	-
	KP	-	110	125	180	160	250	280	-	-
	KQ	-	95	110	142	-	-	260	-	-
	KW	-	45°	45°	45°	45°	45°	45°	-	-
FB	KA	-	80	89	98	-	110	-	-	-
	KB	-	9	10	10	-	17	-	-	-
	KC	-	5	5	5	-	6	-	-	-
	KN	-	95	110	130	-	130	-	-	-
	KM	-	115	130	165	-	165	-	-	-
	KO	-	9.5 x 4	9.5 x 4	11 x 4	-	11 x 4	-	-	-
	KP	-	140	160	200	-	200	-	-	-
	KW	-	45°	45°	45°	-	45°	-	-	-

PC & CMRV Dimensions

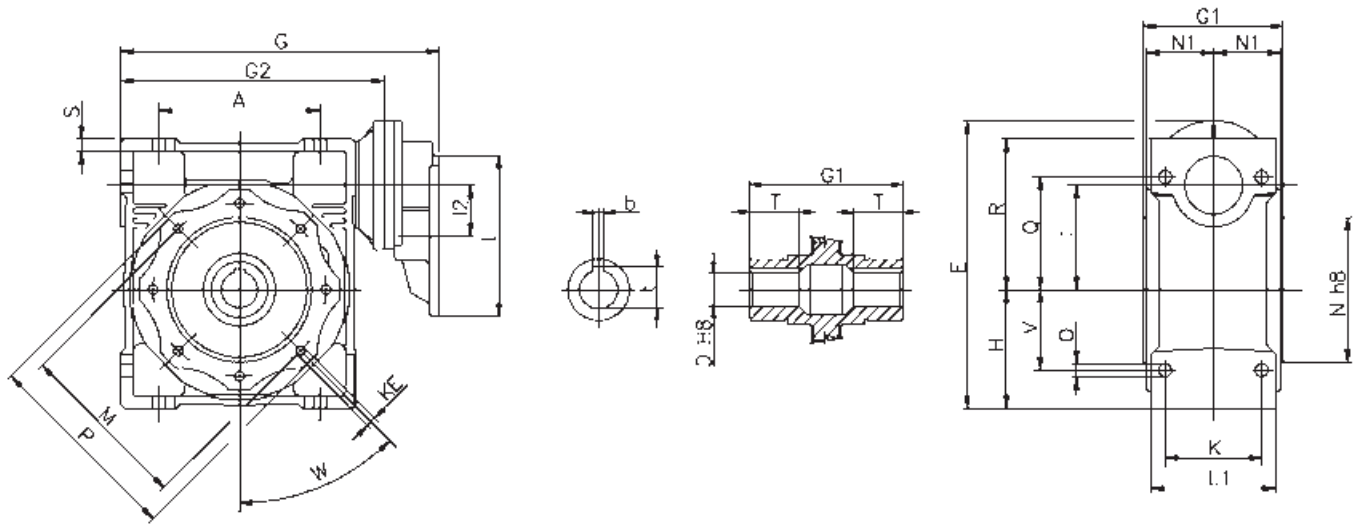

	PC063+CMRV			PC071+CMRV				PC80 / PC090+CMRV			
	040	050	063	050	063	075	090	075	090	110	130
A	70	80	100	80	100	120	140	120	140	170	200
E	147	167	192	177.5	202.5	228.5	260.5	241	273	317.5	357.5
G	165	185	212	193	220	251.5	285.5	267.5	301.5	356.5	396.5
G1	78	92	112	92	112	120	140	120	140	155	170
G2	120	140	167	140	167	198.5	232.5	198.5	232.5	287.5	327.5
H	50	60	72	60	72	86	103	86	103	127.5	147.5
I	40	50	63	50	63	75	90	75	90	110	130
I2	40	40	40	50	50	50	50	63	63	63	63
L	140	140	140	160	160	160	160	200	200	200	200
L1	71	85	103	85	103	112	130	112	130	144	155
K	60	70	85	70	85	90	100	90	100	115	120
KE	M6*10(4)	M8*10(4)	M8*14(8)	M8*10(4)	M8*14(8)	M8*14(8)	M10*18(8)	M8*14(8)	M10*18(8)	M10*18(8)	M12*21(8)
M	75	85	95	85	95	115	130	115	130	165	215
N	60	70	80	70	80	95	110	95	110	130	180
N1	36.5	43.5	53	43.5	53	57	67	57	67	74	81
O	6.5	8.5	8.5	8.5	8.5	11.5	13	11.5	13	14	16
P	87	100	110	100	110	140	160	140	160	200	250
Q	55	64	80	64	80	93	102	93	102	125	140
R	71.5	84	102	84	102	119	135	119	135	167.5	187.5
S	6.5	7	8	7	8	10	11	10	11	14.5	15.5
T	26	30	36	30	36	40	45	40	45	50	60
V	35	40	50	40	50	60	70	60	70	85	100
W	45°	45°	45°	45°	45°	45°	45°	45°	45°	45°	45°
D	18	25	25	25	25	28	35	28	35	42	45
b	6	8	8	8	8	8	10	8	10	12	14
t	20.8	28.3	28.3	28.3	28.3	31.3	38.3	31.3	38.3	45.3	48.8
kg	3.4	4.6	7.3	5.1	7.8	10.6	14.6	12.4	16.4	38.4	51.4

kg = Weight without motor

For the dimensions of the output flanges, please consider the drawing of relevant CMRV size.

For the dimensions of the hollow shafts in option, please consider the drawing of relevant CMRV size.

For the dimensions of the double extension worm shafts, please consider the drawing of relevant CMRV size.

All dimensions in millimetres unless otherwise stated. Every effort has been taken to ensure that the data listed in this catalogue is correct. Challenge accepts no liability for any inaccuracies or damage caused.

CMRV & CMRV Dimensions

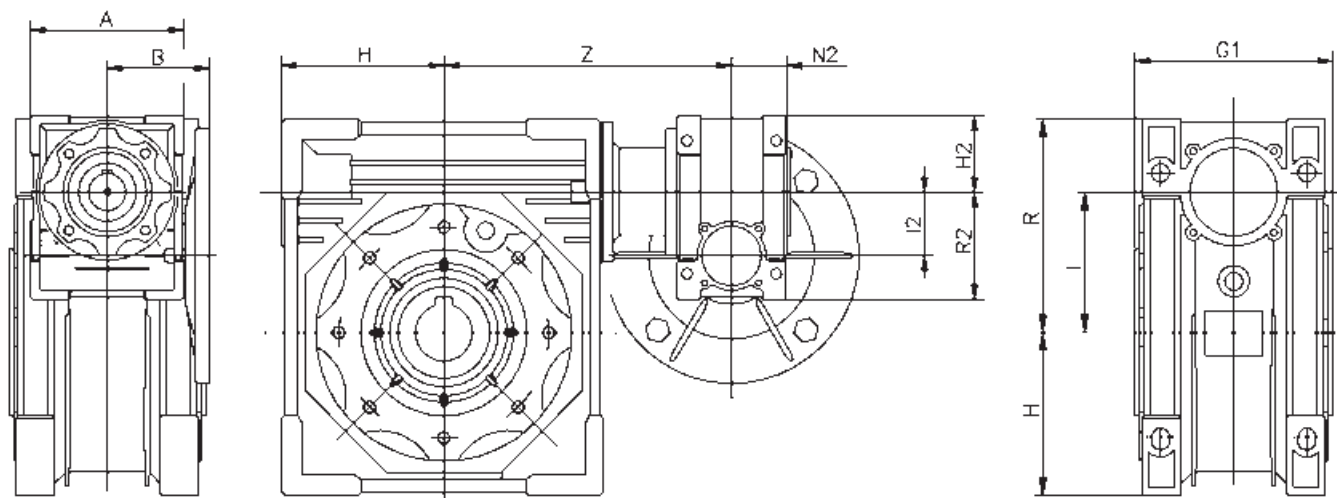

	CMRV-CMRV									
	025-030	025-040	030-040	030-050	030-063	040-075	040-09	050-110	063-130	063-150
A	70	70	80	80	80	100	100	120	144	144
B	45	45	55	55	55	70	70	80	95	95
G1	63	78	78	92	112	120	140	155	170	200
H	40	50	50	60	72	86	103	127.5	147.5	170
I	30	40	40	50	63	75	90	110	130	150
R	57	71.5	71.5	84	102	119	135	167.5	187.5	230
H2	35	35	40	40	40	50	50	60	72	72
I2	25	25	30	30	30	40	40	50	63	63
N2	22.5	22.5	29	29	29	36.5	36.5	43.5	53	53
R2	48	48	57	57	57	71.5	71.5	84	102	102
Z	100	115	122	132	145	167.5	184.5	226	245	275
kg	1.9	3	3.5	4.7	7.4	11.3	15.3	38.5	54.2	90.2

kg = Weight without motor

CRV & CRV-CMRV Dimensions

CRV

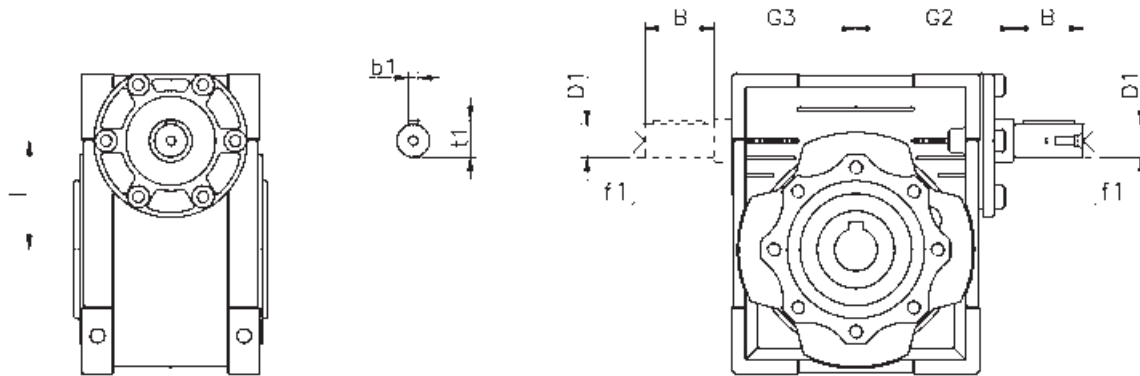

CRV	030	040	050	063	075	090	110	130	150
B	20	23	30	40	50	50	60	80	80
D1	9 j6	11 j6	14 j6	19 j6	24 j6	24 j6	28 j6	30 j6	35 j6
G2	51	60	74	90	105	125	142	162	195
G3	45	53	64	75	90	108	135	155	175
l	30	40	50	63	75	90	110	130	150
b1	3	4	5	6	8	8	8	8	10
f1	-	-	M6	M6	M8	M8	M10	M10	M12
t1	10,2	12,5	16	21,5	27	27	31	33	38

CRV-CMRV

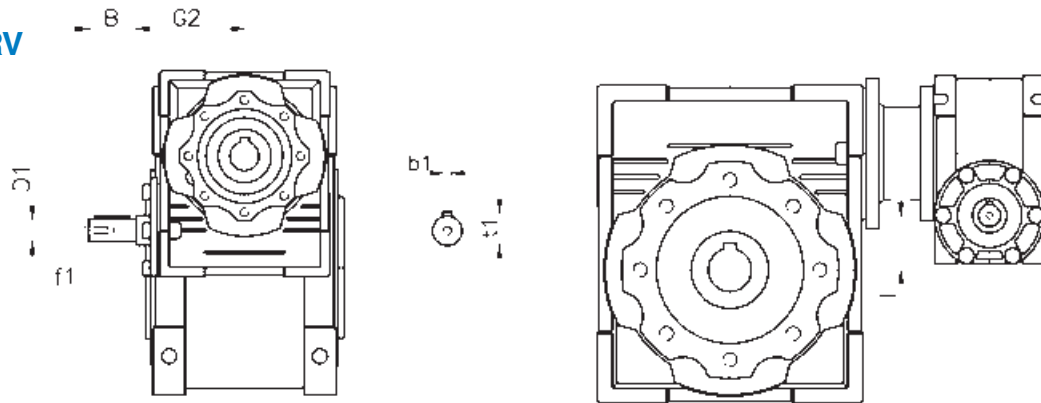

CRV-CMRV	030-040	030-050	030-063	040-075	040-090	050-110	063-130	063-150
B	20	20	20	23	23	30	40	40
D1	9 j6	9 j6	9 j6	11 j6	11 j6	14 j6	19 j6	19 j6
G2	51	51	51	60	60	74	90	90
l	10	20	33	35	50	60	67	87
b1	3	3	3	4	4	5	6	6
f1	-	-	-	-	-	M6	M6	M6
t1	10,2	10,2	10,2	12,5	12,5	16	21,5	21,5

For the missing dimensions, please consult the CMRV size drawing.

Output Shafts & CTA Torque Arms

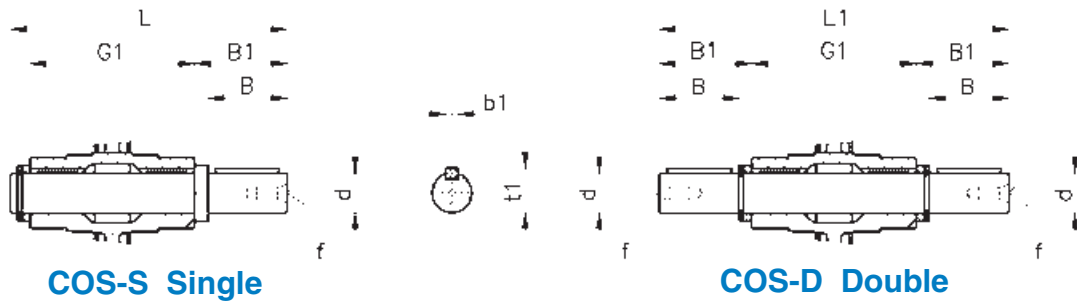

COS-S Single

COS-D Double

Size	d	B	B1	G1	L	L1	f	b1	t1
025	11g6 (9)	23 (25)	25,5 (30)	50	81 (85,5)	101	-	4 (3)	12,5 (10,2)
030	14 h6	30	32,5	63	102	128	M6	5	16
040	18 h6	40	43	78	128	164	M6	6	20,5
050	25 h6	50	53,5	92	153	199	M10	8	28
063	25 h6	50	53,5	112	173	219	M10	8	28
075	28 h6	60	63,5	120	192	247	M10	8	31
090	35 h6	80	84,5	140	234	309	M12	10	38
110	42 h6	80	84,5	155	249	324	M16	12	45
130	45 h6	80	85	170	265	340	M16	14	48,5
150	50 h6	82	87	200	297	374	M16	14	53,5

CTA Torque arms

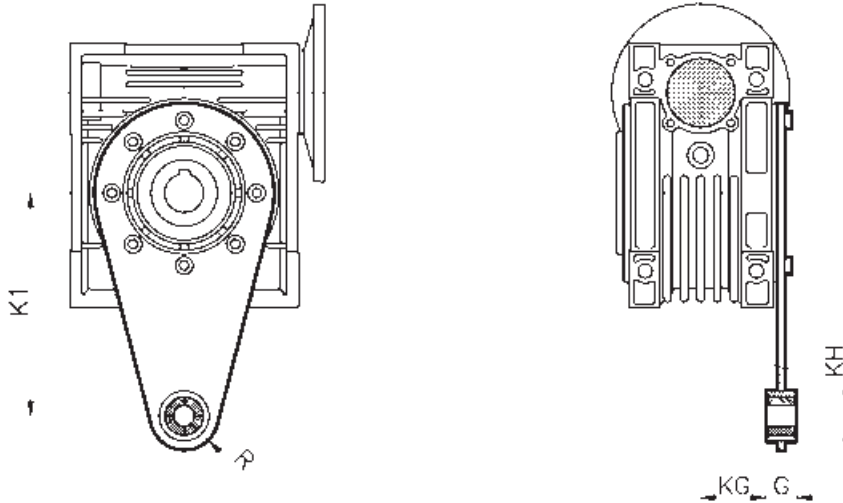

Size	K1	G	Kg	KH	R
025	70	14	17,5	8	15
030	85	14	24	8	15
040	100	14	31,5	10	18
050	100	14	38,5	10	18
063	150	14	49	10	18
075	200	25	47,5	20	30
090	200	25	57,5	20	30
110	250	30	62	25	35
130	250	30	69	25	35
150	250	30	84	25	35

Every effort has been taken to ensure that the data listed in this catalogue is correct. Challenge accepts no liability for any inaccuracies or damage caused. All dimensions in millimetres unless otherwise stated.

Motor Input Flanges PAM B5 & PAM B14

PAM B5

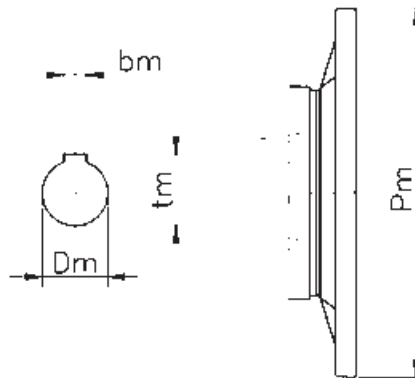

Dimensions

B5	IEC										
	056	063	071	080	090	100	112	132	160	180	200
Pm	120	140	160	200	200	250	250	300	350	350	400
Dm	9	11	14	19	24	28	28	38	42	48	55
bm	3	4	5	6	8	8	8	10	12	14	16
tm	10,4	12,8	16,3	21,8	27,3	31,3	31,3	41,3	45,3	51,8	59,3

PAM B14

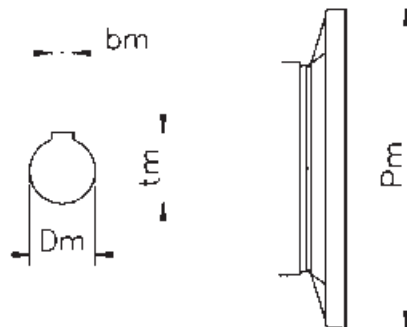

Dimensions

B14	IEC							
	056	063	071	080	090	100	112	132
Pm	80	90	105	120	140	160	160	200
Dm	9	11	14	19	24	28	28	38
bm	3	4	5	6	8	8	8	10
tm	10,4	12,8	16,3	21,8	27,3	31,3	31,3	41,3

Cover & Shaft Sleeves

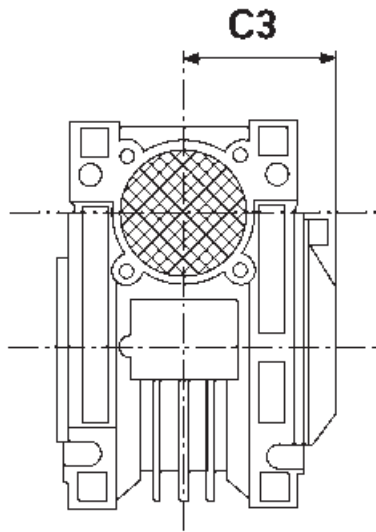

Cover

TYPE	C3
030	43
040	50
050	59
063	70
075	75
090	87
110	95
130	103

CMS Reduction bushing kit

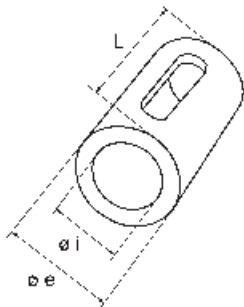

SINGLE SIZE SHAFT SLEEVES				
TYPE	øi/øe	L	KEY	Weight kg
CMS	9/11	20	4/3 x 4 x 11	0.006
CMS	11/14	30	5/4 x 6 x 10	0.015
CMS	14/19	40	6 x 5 x 30	0.045
CMS	19/24	50	6 x 5.5 x 20 8 x 5.5 x 40	0.07
CMS	24/28	60	8 x 9 x 40	0.08
CMS	28/38	80	10 x 7 x 60	0.33
CMS	38/42	110	12/10 x 10 x 48	0.22

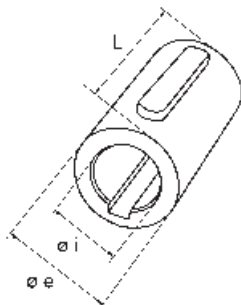

DOUBLE SIZE SHAFT SLEEVES				
TYPE	øi/øe	L	KEY	Weight kg
CMS	9/11	40	6 x 6 x 30	0.06
CMS	11/24	50	8 x 7 x 40	0.12
CMS	19/28	60	8 x 7 x 50	0.6
CMS	24/38	80	10 x 8 x 60	0.44

Drive Design

Drive design

Example:

To design a drive a few simple questions need to be asked, then calculated first.

For example, a belt conveyor needs to be driven by a shaft mounted worm gear unit.

Belt speed required: say for example 55 feet per minute

Diameter of drive roller/drum: say for example 1 foot

Calculation for the output speed the gear unit needs to run at, or the drum speed needs to be, is as follows:

Diameter of drum in feet, multiplied by 3.142 (pi) multiplied by the speed in rev/min, gives you the feet per min / Belt speed,

So, $1 \times 3.142 \times 17.5 \text{ rev/min} = 54.985 \text{ ft per min}$ say 55 feet per min.

Our gear unit output speed needs to be **17.5 rev/min**

If we assume our motor input speed is 1400 rev/min divided by 17.5 rev/min, gives you 80, so the ratio of the gear unit is 80:1.

Now we need to calculate the power required:

To do this we need to calculate the torque in Newton meters (Nm), the calculation is as follows:

Load in lbs multiplied by the radius of the roller/drum gives you the torque required to lift the load vertically.

By exerting a pull around a drum or pulley see Fig 1

Fig 1

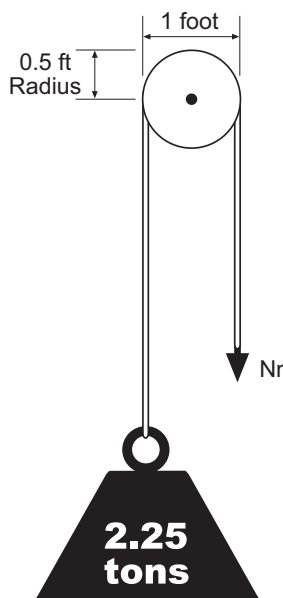

The load including the belt is 2.25 tons.

So, $2240 \text{ lbs} = 1 \text{ ton} \times 2.25 = 5040 \text{ lbs}$ / $2.25 \text{ tons} \times 0.5 \text{ ft radius of roller/drum} = 2520 \text{ lbs ft torque}$ to convert to Nm $\times 1.3558 = 3416 \text{ Nm}$

Now we have to apply a coefficient of friction or rolling friction, Effectively we will lay the lifting torque in Fig 1 flat, as if rotating the illustration 90 degrees clockwise.

So the lifting torque is $3416 \text{ Nm} \times 0.05 = 170.8 \text{ Nm}$ coefficient of friction or rolling friction for this type of application.

We now have a required torque of **170.8 Nm**. What we need to do now is apply a service factor.

Service factors can vary considerably depending on the application.

Example:

Conveyors running 16 hours per day with up to 10 stops and starts per hour would be a service factor of 1.3, therefore we take the required torque of **170.8 Nm multiplied by the 1.3 service factor = 221.39 Nm say 222 Nm** this is called the design power.

We can now look in the catalogue and find a gear unit with a rated torque of 222 Nm or slightly larger with a service factor (f/s) of 1 or more.

The unit we require is a CMRV090 80:1 the catalogue shows this unit rated at .92 kW At 316 Nm torque.

Now we take .92 kW divided by 316 Nm and multiply by 222 Nm = 0.646 kW.

0.92 kW and 0.646 kW motors are none standard so we need to choose a **0.75 kW 4 pole 1400 rev/min motor in a 80B5 output flange and a CMRV090 80:1 B5 80 input flange.**

the actual torque we will get from our selection is 257 Nm which will now give a service factor of 1.5.

Useful formulae:

Feet per minute = diameter of drum/roller x 3.142 ft x rev/min

kW to torque Nm = $\frac{\text{kW} \times 9550}{\text{rpm}}$

Coefficient of friction:

Coefficient of friction varies from application to application, but a general rule for anti friction bearings is 0.01 to 0.05, for example, a chain conveyor on a 5° Incline would use a coefficient of friction equal to 0.05, inclines over 45° should be treated as a straight lift.

Useful Conversion Data

To convert	Multiply by
Force	
lbf to N	4.4482
kgf to N	9.8066
Mass	
oz to grams	28.35
lb to kg	0.4536
tons to tonnes (1000kg)	1.016
tons to short (US) tons	1.12
Powers	
horsepower to kW	0.7457
hp to metric hp	1.014
metric hp to kW	0.735
Pressures	
lb/sq in to kg/sq cm	0.0703
lb/sq ft to kg/sq m	4.88
lb/sq in to ft of water	2.31
lb/sq in to atmospheres	0.0680
Speeds	
ft/sec to m/sec	0.3048
ft/sec to knots	0.592
ft/sec to miles/hr	0.682
ft/min to m/sec	0.0051
knots to miles/hr	1.1515
miles/hr to km/hr	1.6093
knots to km/hr	1.8520
Torque	
lbf ft to Nm	1.3558
kgf m to Nm	9.8066
lbf ft to kgf m	0.1383
Volumes	
cu in to cu cm	16.387
cu ft to cu m	0.0283
cu ft to galls	6.25
cu ft to litres	28.33
pints to litres	0.568

To convert	Multiply by
Volumes cont..	
galls to litres	4.546
Imp galls to US galls	1.2
US barrels to cu m	0.16
N to lbf	0.2248
Ntokgf	0.101972
grams to oz	0.0353
kg to lb	2.205
tonnes to tons (2240lbs)	0.9842
short (US) tons to tons	0.893
kWtohp	1.341
metric hp to hp	0.9862
kW to metric hp	1.359
kg/sq cm to lb/sq in	14.22
kg/sq m to lb/sq ft	0.205
ft of water to lb/sq in	0.433
atmospheres to lb/sq in	14.7
m/sec to ft/sec	3.281
knots toft/sec	1.689
miles/hr to ft/sec	1.467
m/sec to ft/min	196.8
miles/hr to knots	0.868
km/hr to miles/hr	0.6214
km/hr to knots	0.5400
Nm to lbf ft	0.7376
Nm to kgfm	0.1020
kgfmlbfft	7.2330
cu cm to cu in	0.061
cu m to cu ft	35.31
galls to cu ft	0.16
litres to cu ft	0.035
litres to pints	1.76
litres to galls	0.22
US galls to Imp galls	0.833
cu m to US barrels	6.29

The central columns of figures in bold type can be referred in either direction. To the left to convert metres into feet, or to the right to convert feet into metres. For example, five lines down: 5 feet = 1.52 metres, and 5 metres = 16.40 feet.

Feet	Metres	Feet	Metres	Feet	Metres	Feet	Metres
3.28	1	0.30	45.93	14	4.27	88.58	27
6.56	2	0.61	49.21	15	4.57	91.86	28
9.84	3	0.91	52.49	16	4.88	95.14	29
13.12	4	1.22	55.77	17	5.18	98.43	30
16.40	5	1.52	59.06	18	5.49	101.71	31
19.69	6	1.83	62.34	19	5.79	104.99	32
22.97	7	2.13	65.62	20	6.10	108.27	33
26.25	8	2.44	68.90	21	6.40	111.55	34
29.53	9	2.74	72.18	22	6.71	114.83	35
32.81	10	3.05	75.46	23	7.01	118.11	36
36.09	11	3.55	78.74	24	7.32	121.39	37
39.37	12	3.66	82.02	25	7.62	124.67	38
42.65	13	3.96	85.30	26	7.92	127.95	39

 **CHALLENGE**  [®]

